

2SC5440

Silicon NPN triple diffusion mesa type

For horizontal deflection output

■ Features

- High breakdown voltage, and high reliability through the use of a glass passivation layer
- High-speed switching
- Wide area of safe operation (ASO)

■ Absolute Maximum Ratings $T_C = 25^\circ\text{C}$

Parameter	Symbol	Rating	Unit	
Collector to base voltage	V_{CBO}	1 500	V	
Collector to emitter voltage	V_{CES}	1 500	V	
	V_{CEO}	600	V	
Emitter to base voltage	V_{EBO}	7	V	
Peak collector current	I_{CP}	25	A	
Collector current	I_C	15	A	
Base current	I_B	7.5	A	
Collector power dissipation	P_C	$T_C = 25^\circ\text{C}$	60	W
		$T_a = 25^\circ\text{C}$	3.0	
Junction temperature	T_j	150	$^\circ\text{C}$	
Storage temperature	T_{stg}	-55 to +150	$^\circ\text{C}$	

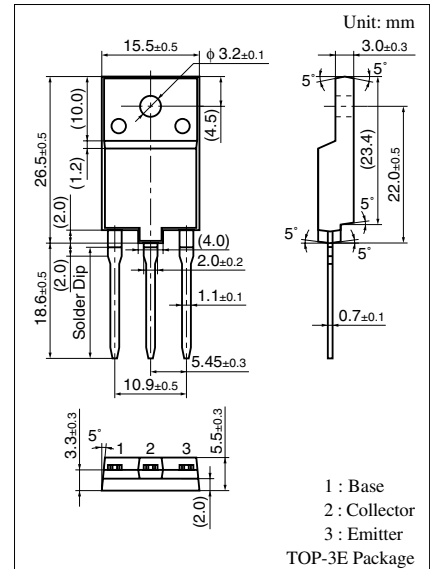

Internal Connection

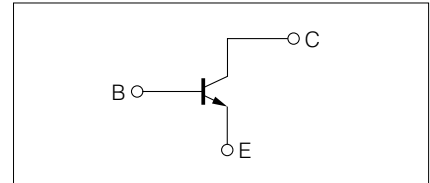

■ Electrical Characteristics $T_C = 25^\circ\text{C}$

Parameter	Symbol	Conditions	Min	Typ	Max	Unit
Collector cutoff current	I_{CBO}	$V_{CB} = 1\ 000\ \text{V}, I_E = 0$			50	μA
		$V_{CB} = 1\ 500\ \text{V}, I_E = 0$			1	mA
Emitter cutoff current	I_{EBO}	$V_{EB} = 7\ \text{V}, I_C = 0$			50	μA
Forward current transfer ratio	h_{FE}	$V_{CE} = 5\ \text{V}, I_C = 7.5\ \text{A}$	5		9	
Collector to emitter saturation voltage	$V_{CE(sat)}$	$I_C = 7.5\ \text{A}, I_B = 1.88\ \text{A}$			3	V
Base to emitter saturation voltage	$V_{BE(sat)}$	$I_C = 7.5\ \text{A}, I_B = 1.88\ \text{A}$			1.5	V
Transition frequency	f_T	$V_{CE} = 10\ \text{V}, I_C = 0.1\ \text{A}, f = 0.5\ \text{MHz}$		3		MHz
Storage time	t_{stg}	$I_C = 7.5\ \text{A}, I_{B1} = 1.88\ \text{A}, I_{B2} = -3.76\ \text{A}$			2.7	μs
Fall time	t_f				0.2	μs

$P_C - T_a$

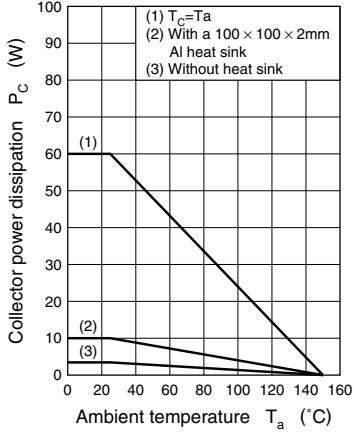

$V_{CE(sat)} - I_C$

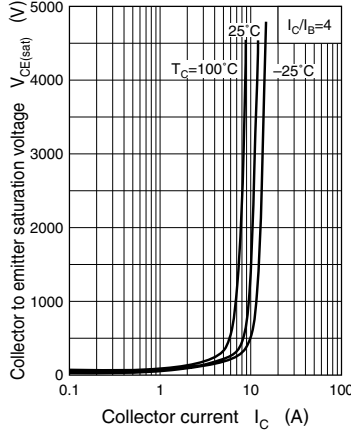

$h_{FE} - I_C$

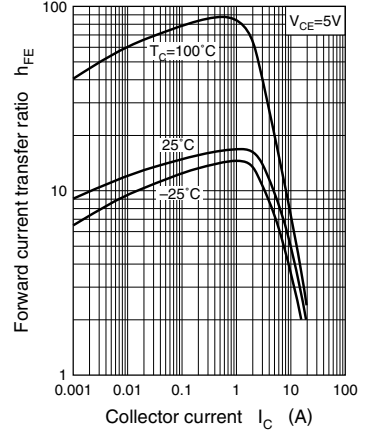

Area of safe operation (ASO)

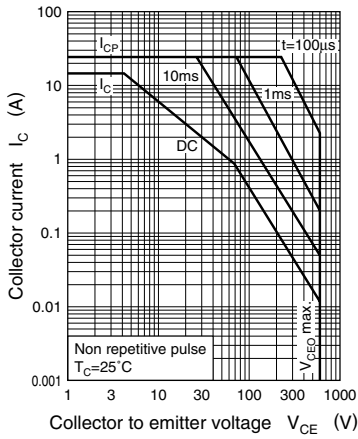

Area of safe operation, horizontal operation ASO

